

Cilindros hidráulicos de simple y doble efecto

Single and double acting hydraulic cylinders

Cilindros estándar de simple efecto
LÁSER

LASER single acting standard cylinders

DISEÑO PARA CILINDROS ØA 25 ▶ 40

DESIGN FOR CYLINDERS ØA 25 ▶ 40

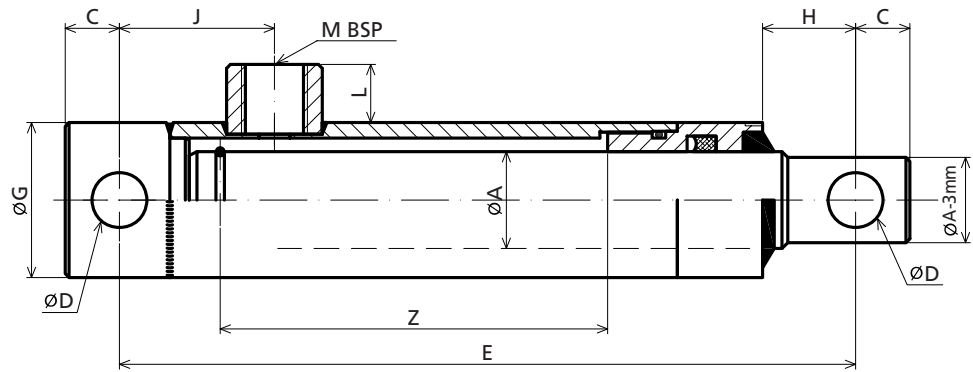

PANDEO | BUCKLING

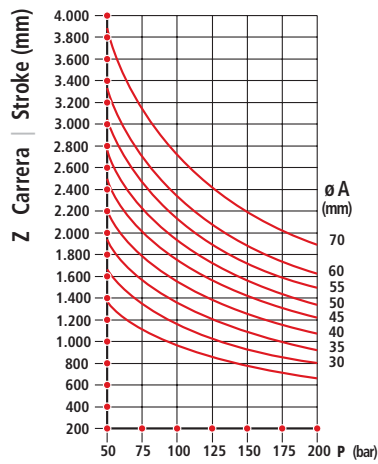

FUERZA DE EMPUJE | UPWARD THRUST

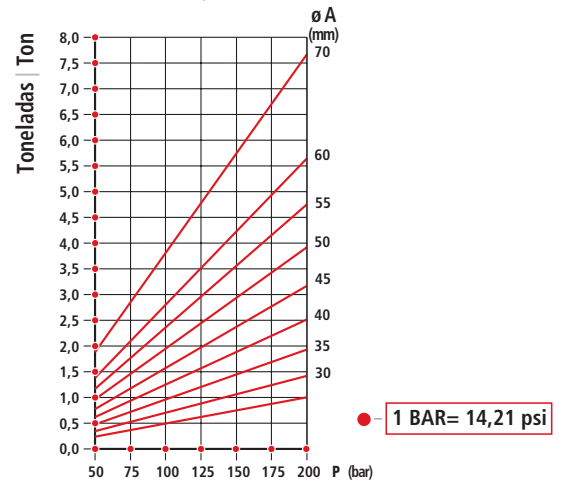

DISEÑO PARA CILINDROS ØA 45 ▶ 70

DESIGN FOR CYLINDERS ØA 45 ▶ 70

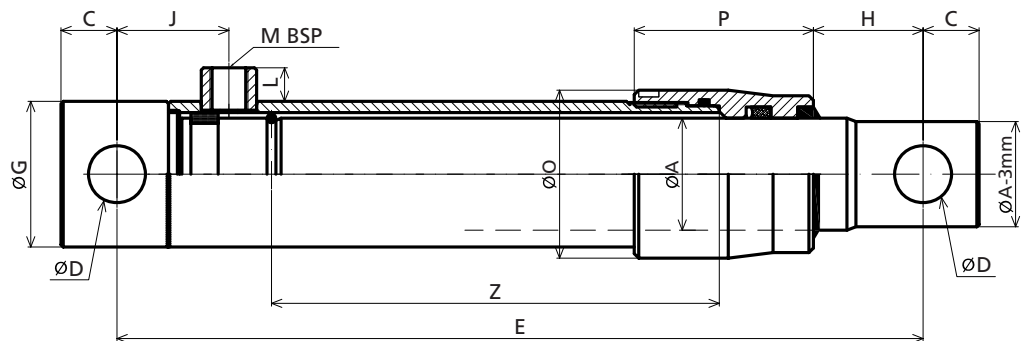

Cilindros hidráulicos de simple y doble efecto

Single and double acting hydraulic cylinders

Cilindros estándar de simple efecto
LÁSER

LASER single acting standard cylinders

01

REF.	Ø A	Z CARRERA STROKE	E	C	D	G	H	J	O	P	L	M	Vol. (L)	Peso Weight (Kg.)
625/10	25	100	190	14	14,2	40	24	40			9,5	1/4	0,08	1,5
625/20		200	290										0,16	2,3
625/30		300	390										0,24	3,0
630/2	30	200	300	17	16,2	50	26	42			15	3/8	0,25	3,6
630/3		300	400										0,38	4,7
630/4		400	500										0,50	6,0
630/5		550	650										0,69	7,6
630/7		700	800										0,88	9,4
635/2	35	200	330	20	20,25	55	32	47			15	3/8	0,32	4,7
635/3		300	430										0,48	6,1
635/4		400	530										0,64	7,5
635/5		550	680										0,87	9,6
635/7		700	830										1,11	11,7
640/2	40	200	330	22	23	60	32	47			15	3/8	0,39	6,0
640/3		300	430										0,59	7,6
640/4		400	530										0,79	9,3
640/5		550	680										1,08	11,7
640/7		700	830										1,37	14,2
645/2	45	200	330	22	23	60	34	47	70	77	15	3/8	0,39	7,0
645/3		300	430										0,59	8,9
645/4		400	530										0,79	10,9
645/5		550	680										1,08	13,7
645/7		700	830										1,37	16,7
650/2	50	200	360	25	25,25	65	49	50	75	80	15	3/8	0,48	8,9
650/3		300	460										0,71	11,2
650/4		400	560										0,95	13,5
650/5		550	710										1,31	16,8
650/7		700	860										1,66	20,4
655/3	55	300	460	25	25,25	70	41	50	85	95	15	3/8	0,85	13,6
655/5		550	710										1,56	20,1
655/7		700	860										1,98	24,2
660/2	60	200	360	25	25,25	75	36	50	90	95	15	3/8	0,66	12,6
660/3		300	460										1,00	15,7
660/4		400	560										1,33	18,7
660/5		550	710										1,83	23,3
660/7		700	860										2,32	28,4
670/3	70	300	495	28	30,5	90	50	58	108	110	17	1/2	1,33	25,1
670/4		400	595										1,77	29,6
670/5		550	745										2,43	36,5
670/7		700	895										3,09	43,4

Unidades en mm. | All measures in mm.

SOMOS LOS ÚNICOS FABRICANTES DE CILINDROS HIDRÁULICOS DEL MUNDO QUE SOLDAMOS CON TECNOLOGÍA LÁSER

WE ARE THE ONLY HYDRAULIC CYLINDER MANUFACTURERS IN THE WORLD THAT WELD WITH LASER TECHNOLOGY

